



OFFLINE COURSE

LAND SURVEYING TRAINING PROGRAM



A Complete Practical Training for Land Surveying Professionals



Auto Level Surveying



Total Station Surveying



DGPS Surveying



Data Collection & Field Book Preparation



AutoCAD & MS Excel for Survey Data



Contouring & Area Calculation



Route Surveying & Setting Out



Reports & Drawing Preparation

01 Auto Level

02 Total Station

03 DGPS

TRAINING MODULE

AutoCAD and MS Excel

Fees ₹25,500/- Duration 2.5 Months

+91 97-111-555-85 | reinforceqst.com



ISO 9001:2015 Training Certified



Actively Learning with Real Time Projects



Practical Learning Environment



Plot 3A, GF, Westend Marg, Lane 2, Near Saket Metro Station Gate No. 2, New Delhi 110030

About us

Reinforce Civiltech Private Limited is an ISO-certified training institute **established in 2016**, dedicated to providing practical and industry-oriented training in the field of construction and civil engineering. Our programs are designed to bridge the gap between academic learning and real-world industry requirements through hands-on training and expert guidance.

Over the years, we have trained and empowered **more than 1 lakh** students and professionals, many of whom are now working with reputed companies across India. We have also provided corporate training to leading companies such as **Patel Engineering, DLF , and Larsen & Toubro (L&T)** , along with conducting **100+ seminars and 500+ workshops** across colleges and construction organizations nationwide.

Vision

Our vision is to empower civil engineering students and working professionals with **practical knowledge and hands-on industry experience**. We aim to deliver training as per industry standards and requirements, helping trainees enhance their skills, improve employability, and secure rewarding career opportunities.

With more than **10 years of experience**, **Reinforce Civiltech Private Limited** has established itself as a trusted training provider in the civil engineering sector, supported by a team of experienced trainers and industry experts.

Training Glimpses



Training Process

This is our tried and tested training process method that helps to provide you with noticeable improvements in efficiency and communication among employees with the practical skills as per construction demand.



On-site Training

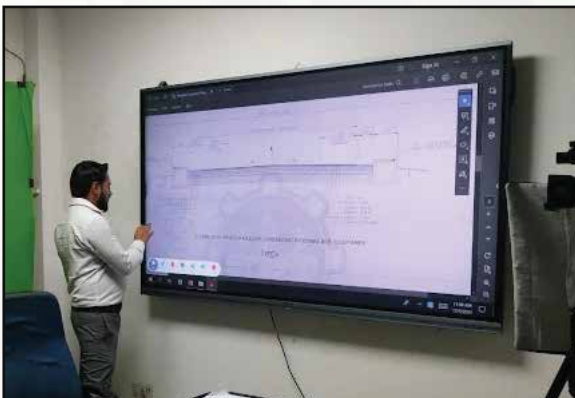

In-Class Training



Assessment & Certification

Professional Training Course

Master the most in-demand skill of Construction Industry, Engineering & Achitecture and boost your career

Get trained from Industry Experts worked at



Training Module

AutoLevel

- 1.introduction of auto level instrument
- 2.Main parts of the auto level instrument
- 3.Diffrent types of levelling staff
- 4.staff reading in m,cm,mm
- 5.Centring and levelling of auto level instrument
- 6.What is mean sea level (Msl)?
- 7.What is reduced level (RL)?
- 8.What is Benchmark and types of Benchmark (BM)?
- 9.What is BS,FS&IS ?
10. Methods of calculating RL
11. HI method
12. Rise and fall method
13. All formulas for calculating RL
14. Methods of error checking of auto level instrument
15. Error checking practically on site
16. How to find out distance from Auto level instrument?
17. What is levelling? principal of levelling?
18. Different types of levelling?



Training Module

AutoLevel

- 19. Practically performing all the types of levelling on site .
- 20. Calculation of all the levelling with standard format on Excel sheet
- 21. What is Contour survey,why we do?
- 22. Practically performing of contour survey on site
- 23. Quantity calculation of cutting and filling in Excel sheet with help of contour survey.
- 24. What is traverse survey,why we do?
- 25. Practically performing of traverse survey on site



Training Module

Total Station

1. Introduction of total station instrument
2. Main parts of total station
3. Function of total station
4. Centring and levelling of total station
5. Tilting of total station
6. Find horizontal, vertical and sloping distance
7. Find horizontal and vertical angle measurement
8. REM- Remote elevation measurement
9. MLM-Missing line measurement
10. PTL-Point to line
11. Area measurement
12. Methods of error checking of total station instrument
13. Practical of error checking on site by angle, distance and level method.
14. What is coordinate and types of coordinate?
15. Different Formets of coordinate
16. Formulas for coordinate calculation
17. Coordinate calculation with true north 90°
18. Coordinate calculation with angle

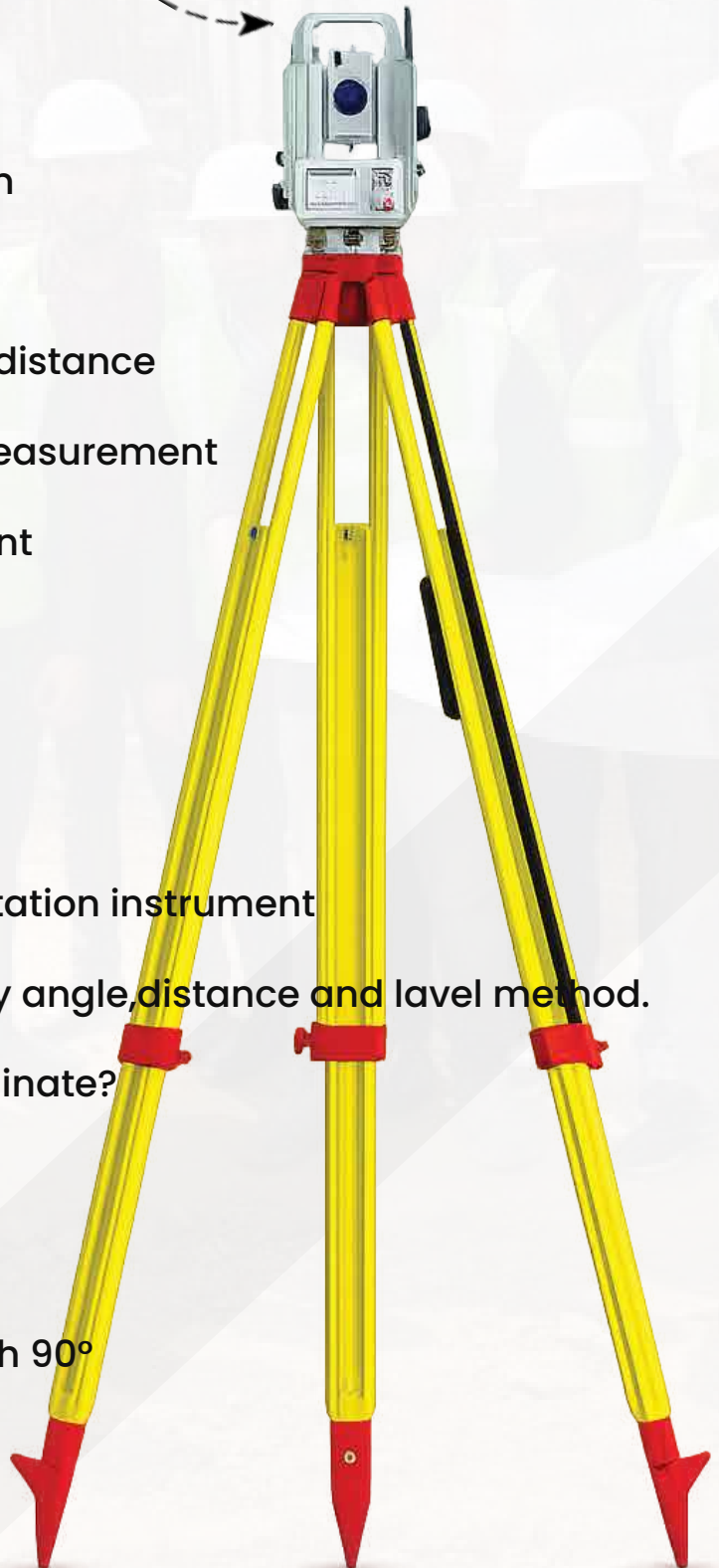

Training Module

Total Station

- 19. All types of set up of total station instrument
- 20. Orientation with angle method
- 21. Orientation with backsite or coordinate method
- 22. Resection by ENZ or cordinate method
- 23. Resection by elevation method
- 24. Topography survey by total station
- 25. Cadastral or boundary survey by total station
- 26. Profile or L section survey by total station
- 27. Cross section survey by total station
- 28. Contour survey by total station
- 29. Traverse survey by total station
- 30. Data transfer or export from total station to USB or pendrive
- 31. File conversation from SDR to Excel, CSV and Auto cad dwg.
- 32. All Excel work and it's important formulas
- 32. All Important commands of auto cad
- 33. Preparation of topography map on AutoCAD by using data of topographic survey



Training Module

Total Station

- 34. Preparation of boundary map on AutoCAD by using data of boundary survey
- 35. Preparation of Contour map on AutoCAD by using data of contour survey
- 36. Preparation of L- section drawing on AutoCAD
- 37. Preparation of cross section drawing on AutoCAD
- 38. Data transfer import from USB to total station
- 40. Stake out of points by total station
- 41. Distance offset by total station
- 42. Define baseline by total station
- 43. Define arc or arc marking
- 44. Layout marking by using total station
- 45. Center line marking by total station



Training Module

DGPS (Differential Global Positioning System)

- 1.Introduction of DGPS instrument
- 2.Main part of DGPS instrument and Accessories
- 3.Diffrence between GPS and DGPS instrument
- 4.How to work Dgps instrument step by step process
- 5.Types of GNSS
- 6.instrument handling details
- 7.Surveying coordinate system
- 8.What is UTM? UTM Zone of india
- 9.Different types of DGPS survey
10. Introduction of Static Survey
 - What is Static Survey?
 - Purpose of Static Survey
 - When We Use Static Survey



Training Module

DGPS (Differential Global Positioning System)

11. Control Point Establishment

- Known Point & Unknown Point
- Benchmark & Control Point
- Selection of Base Location

12. Field Procedure

- Base Setup
- Rover Setup
- Observation Time
- Session Planning
- Data Recording

13. Multi-Day Static Survey

- Continuing Survey Next Day
- Using Same Base Point
- Recording New Sessions
- Precautions

14. Practical Work

- Creating Control Points
- Long Duration Observation
- Real Site Practice



Training Module

DGPS (Differential Global Positioning System)

15. Introduction of RTK Survey

- What is RTK?
- Difference Between RTK & Static Survey
- Applications of RTK

16. RTK Setup

- Base Station Setup
- Rover Configuration
- Radio Connection
- NTRIP Connection

17. RTK Field Work

- Point Survey
- Topographic Survey
- Stake Out
- Road Alignment Survey
- Boundary Survey
- Contour survey

18. Accuracy Checking

- Check Shot
- Point Verification
- Re-Observation



Training Module

DGPS (Differential Global Positioning System)

- 19. DGPS software introduction
- 20. DGPS data download processing
- 21. Static survey data processing
- 22. RTK survey data processing
- 23. Survey Data import and export in DGPS instrument
- 24. Data file convert into CSV, dwg, dxf
- 25. Common DGPS error and problem solving
- 26. Field Practical Activities
 - Base Setup Practice
 - Rover Operation
 - Static Observation
 - RTK Survey
 - Topographic Survey
 - Stakeout Practice
 - Road Survey
 - Coordinate Transfer
 - Control Point Creation
 - All cogo function



Why Learn Land Surveying?



**High
Demand
Skill**



**On-Site
Learning**



**Used in
Various
Projects**



**Opportunities
in India
& Abroad**



**Learn
Modern
instruments**



**Improve
Technical
Knowledge**



**Better
Salary
Growth**



**For both
Fresher &
Professionals**

Career Scope After Training

You can Become:

Land
Surveyor

Site Survey
Engineer

Highway
Surveyor

Bridge Survey
Engineer

DGPS
Surveyor

Total Station
Operator

Layout
Engineer

GIS & Mapping
Assistant

Infrastructure
Survey Technician

Opportunities available in Infrastructure, Highway, Bridge, Metro, Building & Industrial Projects.

Industries Where Surveyors Work



**Building
Construction
Projects**

**Highway &
Expressway
Projects**



**Railway,
Metro & Bridge
Projects**

**Mining &
Infrastructure
Projects**



Who Can Join This Training



**10th, 12th
Students**



**ITI/ Diploma
/ B-Tech
Students**



**Civil
Engineering
Students**



**Working
Professionals**

Countries with High Demand



Australia



Canada



New Zealand



United Arab Emirates



Saudi Arabia



United States



Germany



Qatar



Singapore



Oman



Kuwait



Norway



Sweden



South Africa

Features of the Program

- Practical Site Oriented Training
- Live Instrument Handling
- Real Project Based Learning
- Industry Experienced Trainers
- AutoCAD & Excel Included
- Weekly Practical Sessions
- ISO Authorized Certification
- Interview Preparation Support
- Job Assistance